



**KIESELMANN**  
FLUID PROCESS GROUP

## Operating instructions

- Translation of the original -

**GEMBRA**

**Aseptic Single seat valve**

**Type: 583x**



# 1. List of contents

1.	List of contents .....	1
2.	Information for your safety.....	2
3.	Marking of security instructions in the operating manual .....	2
4.	Safety instructions .....	3
4.1	Field of application .....	3
4.2	General safety instructions.....	3
4.3	General notes .....	3
5.	Function .....	4
5.1	Functional description .....	4
5.1.1	Actuator: air open - spring close .....	4
5.1.2	Actuator: spring open - air close .....	4
5.1.3	Actuator: air open - air close .....	4
6.	Installation informations.....	4
6.1	Installation instructions.....	4
6.2	Welding guidelines.....	4
7.	Maintenance.....	4
7.1	Maintenance .....	4
7.2	Cleaning.....	4
8.	Technical data.....	5
9.	Control system - and interrogation system.....	5
9.1	Special features valve control -optional- .....	5
9.2	Proximity switch receiver set -optional-.....	5
10.	Pneumatic valve actuation .....	6
10.1	Actuator: air open - spring close (Lö- Fs).....	6
10.2	Actuator: spring open - air close (Fö - Ls).....	6
10.3	Actuator: air open - air close (Lö - Ls).....	6
11.	Disassembly and assembly.....	7
11.1	Disassembly valve insert VE.....	7
11.2	Assembly .....	7
11.3	Assembly K-Flex - seal (D1) .....	7
11.4	Assembly sealing ring (D1).....	7
11.5	Assemble the valve insert (VE) into the valve housing (VG).....	8
12.	Drawing .....	9
12.1	Dimensions .....	10
13.	Manufacturing .....	11
13.1	Structure of Article number .....	11
14.	Spare parts list .....	12
14.1	GEMBRA Aseptic Single seat valve (1.4404 / AISI316L) .....	12
14.2	Valve insert .....	13
14.3	Seal kit .....	13
15.	Declaration of conformity.....	14

## 2. Information for your safety

We are pleased that you have decided for a high-class KIESELMANN product. With correct application and adequate maintenance, our products provide long time and reliable operation.



Before installation and initiation, please carefully read this instruction manual and the security advices contained in it. This guarantees reliable and safe operation of this product and your plant respectively. Please note that an incorrect application of the process components may lead to great material damages and personal injury.

**In case of damages caused by non observance of this instruction manual, incorrect initiation, handling or external interference, guarantee and warranty will lapse!**

Our products are produced, mounted and tested with high diligence. However, if there is still a reason for complaint, we will naturally try to give you entire satisfaction within the scope of our warranty. We will be at your disposal also after expiration of the warranty. In addition, you will also find all necessary instructions and spare part data for maintenance in this instruction manual. If you don't want to carry out the maintenance by yourself, our KIESELMANN service team will naturally be at your disposal.

## 3. Marking of security instructions in the operating manual

Hints are available in the chapter "safety instructions" or directly before the respective operation instruction. The hints are highlighted with a danger symbol and a signal word. Texts beside these symbols have to be read and adhered to by all means. Please continue with the text and with the handling at the valve only afterwards.

Symbol	Signal word	Meaning
	<b>DANGER</b>	Imminent danger which may cause severe personal injury or death.
	<b>ATTENTION</b>	Dangerous situation which may cause slight personal injury or material damages.
	<b>NOTE</b>	Marks application hints and other information which is particularly useful.

## 4. Safety instructions

### 4.1 Field of application

The valve is utilised as a pneumatically controlled shut-off valve in food and beverage as well as in pharmaceutical, biotechnological and chemical industries.

The valve is designed for media characteristics according to article 9 of DGRL 97/23/EG for group 2 (media condition gaseous or liquid).



#### ATTENTION

- To avoid danger and damage, the fitting must be used in accordance with the safety instructions and technical data contained in the operating instructions.

### 4.2 General safety instructions



#### DANGER

- Danger of crushing or amputating limbs.  
Do not reach into the valve housing when in pneumatic mode.
- When removing the valve or valve components from the system, there is a danger of injury from escaping liquids or gases.  
Only dismantle when you are absolutely sure that the system is depressurized and free of liquids and gases.
- Danger of scalding and burns to parts of your body from liquids escaping from the leakage drain (L) (Fig. 8 /Page 9).  
The splash protection fixtures must always be attached to the leakage drain (L).
- The actuation can be dismantled.  
Danger of injury by prestressed pressure spring. Observe separate installation instructions.  
We recommend having the manufacturer do the maintenance work required for the actuation.



#### ATTENTION

- To avoid air leaking, only use pneumatic connection parts that have an O-ring seal facing the even surface.
- When mounting the clamps, the max. torque must not be exceeded (see technical Data).
- Steps should be taken to ensure that no external forces are exerted on the fitting.

### 4.3 General notes



#### NOTE

- All data are in line with the current state of development. Subject to change as a result of technical progress.

## 5. Function



Fig. 1

### 5.1 Functional description

The valve is utilised as a pneumatically controlled shut-off valve. Leakage detection takes place via the leakage outlet (L) at the lantern.

#### 5.1.1 Actuator: air open - spring close

The valve opens with control air and closes with spring power by means of a lift drive.

#### 5.1.2 Actuator: spring open - air close

The valve opens with spring power and closes with control air by means of a lift drive.

#### 5.1.3 Actuator: air open - air close

The valve opens and closes with control air by means of a lift drive.

## 6. Installation informations

### 6.1 Installation instructions

The valve must be installed vertically with the actuator at the upwards. Liquid must be able to flow freely from the valve housing. In order to obviate damages, the integration of the pipeline has to be carried out without stress.

### 6.2 Welding guidelines

- Sealing elements integrated in weld components must generally be removed prior to welding.
- To prevent damage, welding should be undertaken by certified personnel (EN287).
- Use the TIG (tungsten inert gas) welding process.



#### NOTE

Impurities can cause damage to the seals. Clean inside areas prior to assembly.

## 7. Maintenance

### 7.1 Maintenance

The maintenance intervals depend on the operating conditions:

- temperature, temperature-intervals
- medium and cleaning medium
- pressure
- opening frequency

We recommend replacing the seals every 2 years. The user, however should establish appropriate maintenance intervals according to the condition of the seals.



#### NOTE

EPDM; Viton; K-flex; NBR; HNBR  
Silicone  
Thread

⇒

⇒

⇒

#### Lubricant recommendation

Klüber Paraliq GTE703\*

Klüber Sintheso pro AA2\*

Interflon Food\*

\*)It is only permitted to use approved lubricants, if the respective fitting is used for the production of food or drink. Please observe the relevant safety data sheets of the manufacturers of lubricants.

### 7.2 Cleaning

The upper and lower process housing is cleaned via pipeline cleaning.

## 8. Technical data

<b>Model:</b>	Single seat valve			
<b>Valve size:</b>	DN 40 - 80			
<b>Connection:</b>	Welding end DIN11850 series 2			
<b>Temperature range:</b>	Ambient temperature:	+4° to +45°C		
	Product temperature:	+0° to +95°C medium dependent +140°C short time (30min)		
	Sterilization temperature:			
<b>Operating pressure:</b>	DN40 - 65	= max. 10 bar		
	DN80	= max. 8 bar		
<b>Cleaning pressure:</b>	3 bar			
<b>Pressure resistance:</b>	30 bar			
<b>Vacuum:</b>	1,5 - 10 <sup>-6</sup> mbar x 1/s (test pressure 0,5mbar)			
<b>Control air pressure:</b>	5,5 - 8,0 bar			
<b>Quality of control air:</b>	ISO 8573-1 : 2001 quality class 3			
<b>Material:</b>	<b>in product contact</b>	<b>not in product contact</b>		
<b>Stainless steel:</b>	1.4404 / AISI316L	1.4301 / AISI304		
<b>Surfaces:</b>	RA ≤0,8µm e-pol.	metallic bright, e-pol.		
<b>Seals:</b>	k-flex (FDA) 150°C EPDM (FDA) 140°C PTFE	EPDM		
<b>Tightening moment:</b>	Retaining clamp: Dimension nominal			
Torque in Nm	DN 40	DN 50	DN 65	DN 80
	15	15	25	20
<b>Valve lift (mm)</b>	DN 40	DN 50	DN 65	DN 80
Valve stroke	18	18	27	27

## 9. Control system - and interrogation system

### 9.1 Special features valve control -optional-

Optionally, modular valve control systems can be installed to the actuator for reading and actuating valve positions. The standard version is a closed system with SPS or ASI-bus switch-on electronics, and integrated 3/2-way solenoid valves. For tough operating conditions we recommend employing a high-grade steel cover.

### 9.2 Proximity switch receiver set -optional-

For the acquisition of the valve positions over inductive initiators, a limit switch support is mounted on the actuation. The enquiry takes place over the position of the piston rod.

# 10. Pneumatic valve actuation

## 10.1 Actuator: air open - spring close (Lö - Fs)

Valve function	pneumatic Control with MV in Control unit (Fig. 2 /Page 8)	pneumatic Control with external solenoid valve (MV) (Fig. 2 /Page 8)
Valve "OPEN"	control air feed P → MV1 → P1/LA2 Valve is opening by control air	control air feed external MV → LA2 Valve is opening by control air
Valve "CLOSED"	de-aeration LA2/P1 → MV1 → R Valve is closing by spring	de-aeration LA2 → external MV Valve is closing by spring

## 10.2 Actuator: spring open - air close (Fö - Ls)

Valve function	pneumatic Control with MV in Control unit (Fig. 2 /Page 8)	pneumatic Control with external solenoid valve (MV) (Fig. 2 /Page 8)
Valve "CLOSED"	control air feed P → MV1 → P1/LA1 Valve is closing by control air	control air feed external MV → LA1 Valve is closing by control air
Valve "OPEN"	de-aeration P1/LA1 → MV1 → R Valve is opening by spring	de-aeration LA1 → external MV Valve is opening by spring

## 10.3 Actuator: air open - air close (Lö - Ls)

Valve function	pneumatic Control with MV in Control unit (Fig. 2 /Page 8)	pneumatic Control with external solenoid valve (MV) (Fig. 2 /Page 8)
Valve "OPEN"	control air feed P → MV1 → P1/LA2 Valve is opening by control air	control air feed external MV → LA2 Valve is opening by control air
Valve "CLOSED"	de-aeration P → MV3 → P3/LA1 Valve is closing by control air	de-aeration external MV → LA1 Valve is closing by control air

Control unit with Solenoid valve  
 MV = Solenoid valve  
 R = de-aeration, sound absorber  
 P = compressed-air inlet (control unit)  
 LA = compressed air inlet (actuation)  
 S = slide switch - manual control (solenoid valves)

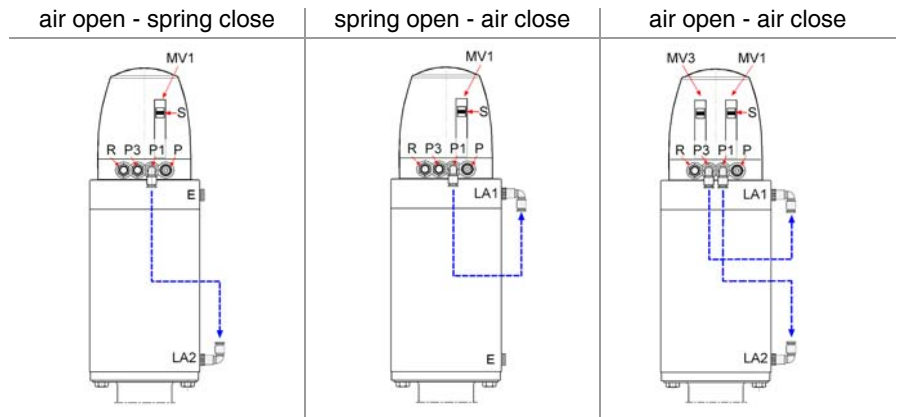

Control head with Initiators

I = Initiators  
 H = Angle bracket  
 E = de-aeration  
 LA = Air connection

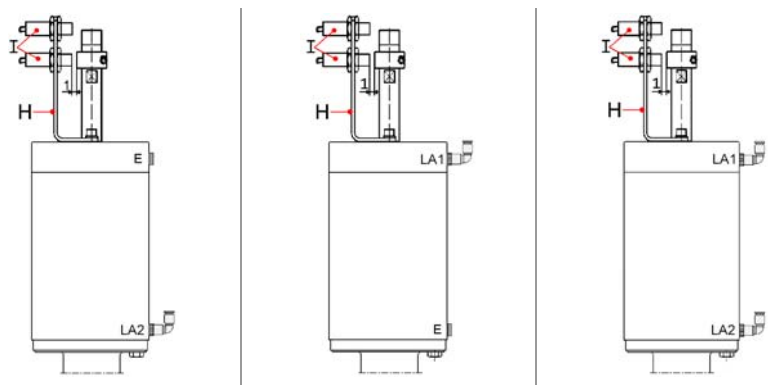

Fig. 2

## 11. Disassembly and assembly

(see Fig. 9 /Page 10) **11.1 Disassembly valve insert VE**



### NOTE

*Dismount control air, steam, condensate pipelines and electric lines, complete proximity switch mounting or control heads.*

Wrench size		1	2	3	4	B
SW						
DN40		19	27	17	17	ø7
DN50		19	27	17	17	ø7
DN65		19	24	17	17	ø7
DN80		27	30	17	17	ø8

### Dismount valve insert with actuator lö-fs

- Connect the compressed air (P) to the air connection (LA2) thereby the piston moves toward X.
- Remove retaining clamp (4) and pull out carefully and without rotary movement the valve insert (VE) from the valve housing (VG).
- Disconnect the compressed air (P) from the air connection (LA2) thereby the piston moves against toward X.

### Dismount valve insert (VE) with actuator Is-fö and lö-Is

- Remove retaining clamp (4) and pull out carefully and without rotary movement the valve insert (VE) from the valve housing (VG).

## 11.2 Exchanging seals

(see Fig. 9 /Page 10) • Screw off piston plate (1) while holding against at the wrench size (SW2).

- Dismount sealing (D1).
- Screw off piston (2) at the wrench size (SW2), while holding against with round rod 8mm at drilling (B1).
- Take off carefully the diaphragm (D2) from the upper piston (3) and the lantern (5).
- Screw off locking screw (8).
- Loosen screws (9) and pull off lantern (5).
- Dismount plain bearing (D3) and O-Ring (D4).

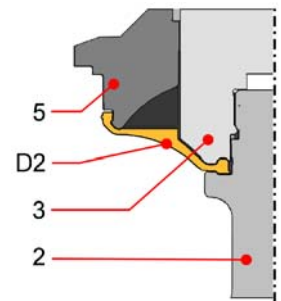

Fig. 3

## 11.3 Assembly

- Thoroughly clean and slightly lubricate mounting areas and running surfaces. Assemble in reverse order.



### NOTE

*During assembly, tie diaphragm (D2) carefully on lantern (5) and on the upper piston (3). Fig. 3 /Page 7*

## Centering ring

DN	Order number
DN40	5620 051 025-020
DN50	5620 051 025-020
DN65	5620 065 025-020
DN80	5620 080 025-020
DN100	-----

## 11.4 Assembly K-Flex - seal (D1)

- Fit the O-Ring into the k-flex seal.
- Assemble the ring shells as in the Fig. 4 /Page 7 in the order A, B, C, D

## 11.5 Assembly sealing ring (D1)

- Screw together piston plate (1) and piston (2) manually to metallic stop position without sealing ring and carry out colour marking (Fig. 5 /Page 7).
- Once again screw off piston plate (1) from piston (2).
- Push sealing (D1) on piston (2) and manually screw the piston plates (1) into the pistons (2).
- For centring the seal (D1) on piston (1), the centering ring has to be placed as shown in Fig. 5 /Page 7.
- Stretch the spanner flat (SW1) with soft braces in bench vice and screw in piston (2) over spanner flat (SW2) until marking.

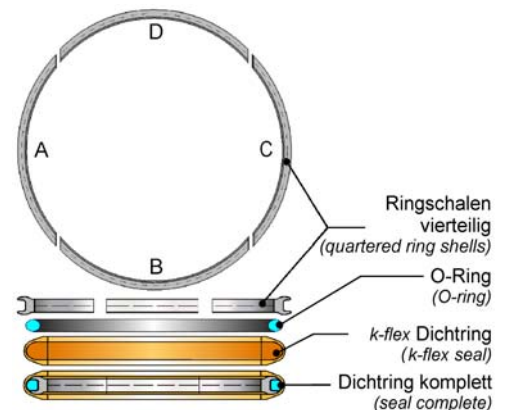

Fig. 4

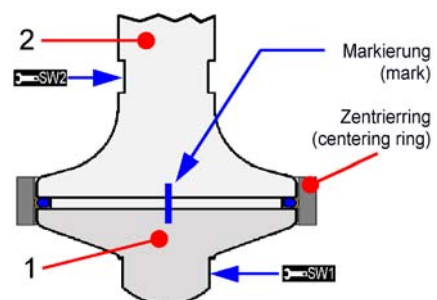

Fig. 5



## 11.6 Assemble the valve insert (VE) into the valve housing (VG)

### ➤ Adjust the installation position of the piston with the mounting tool (MW)

MW



Mounting tool MW for GEMBRA Single seat valves	
DN40 - DN65	Art.-No.: 5836 000 065-000
DN80	Art.-No.: 5836 000 080-000

#### Kind of actuator: air open - spring close

- Connect the compressed air (P) to the air connection (LA2) thereby the piston moves toward X.
- Unscrew the cap (14).
- Screw in the mounting tool (MW) as far as possible into the spindle (11).
- Disconnect the compressed air (P) from the air connection (LA2) thereby the valve drives into installation position.

#### Kind of actuator: air close - spring open air close - air open

- Unscrew the cap (14).
- Screw in the mounting tool (MW) as far as possible into the spindle (11).
- Connect the compressed air (P) to the air connection (LA1 air close-spring open) and (LA2 air open-air close) respectively. Fig. 2 /Page 6
- The valve drives into installation position.



#### NOTE

In this valve position the diaphragm (D2) is in its basic position and is optimally compressed between lantern and housing.

### ➤ Adjust the installation position of the piston without the mounting tool (MW)

- Connect compressed air (P) to the throttle valve (LA1 Is-fö) and (LA2 lö-Is / lö-fs) respectively.
- According to kind of the actuator the piston drives out or in.
- Close the throttle valve at (LA1 or LA2) with a screwdriver.
- Disconnect the compressed air at the throttle valve (LA1 or LA2).
- The piston stops in the position. Position a calliper on the adjustment dimension M1 or M2.
- Slowly open the throttle valve at (LA1 or LA2), so that the piston drives out or in.
- Close the throttle at the position M1 respectively M2. (If an control head is assembled, the adjustment dimension M1 is measured between the actuator and the pin (8).

	Bore	adjustment dimension for the installation position	
	B	M1	M2
DN40	ø7	18,5	107
DN50	ø7	18,5	107
DN65	ø8	29	104
DN80	ø8	35	98



#### NOTE

In this valve position the diaphragm (D2) is in its basic position and is optimally compressed between lantern and housing.

#### Assemble the valve insert into the valve housing

- Carefully install the valve insert in the housing.



#### NOTE

When installing the valve seat, do not damage the sealing surfaces on the piston and the housing as well as the seals.

- Assemble the retaining clamp (4) (Please note the torque data! See the tightening moment in technical data).
- Slowly open the throttle valve again. The piston drives into its basic position.
- Check the valve functions.

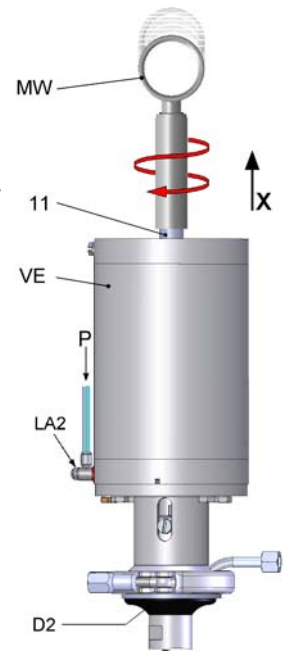

Actuator: lö-fs Fig. 6

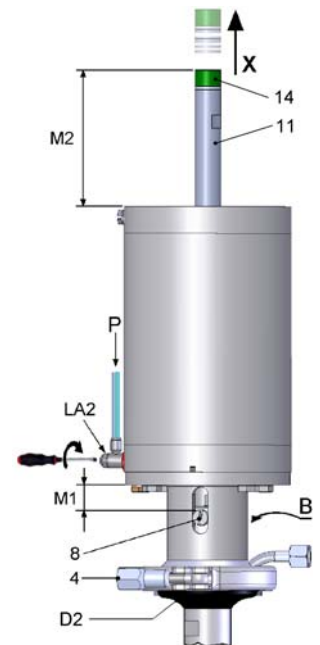

Actuator: lö-fs Fig. 7

## 12. Drawing

### ► Aseptic Angle valve and T-valve GEMBRA Type 5836 and Type 5838

*P* = Central air supply

*P1* = Control air - Valve stroke

*LA1* = air open-spring close - De-aeration

= spring open-air close - Valve stroke

= air open-air close - Valve stroke

*LA2* = air open-spring close - Valve stroke

= spring open-air close - De-aeration

= air open-air close - Valve stroke

*A1* = Control head

*A2* = Proximity switch mounting

*L* = Leakage tell tale G1/4

*VE* = Valve insert

*VG* = Valve housing

*4* = Retaining clamp

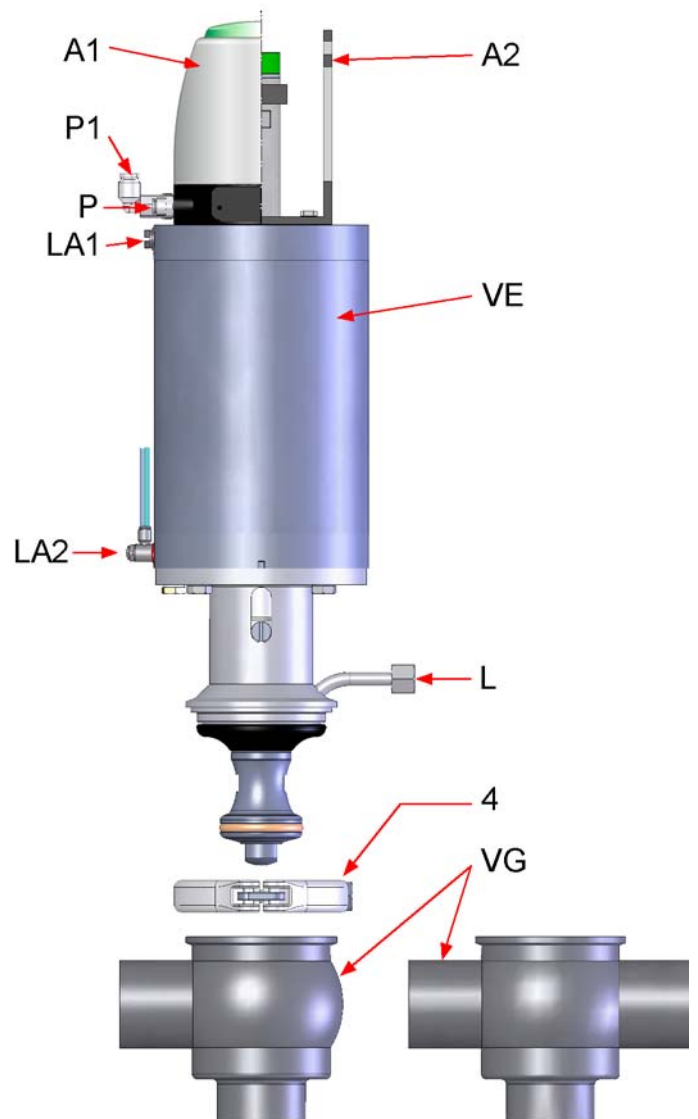

Fig. 8

➤ **Valve inserts**

- 1) Piston plate lower
- 2) Piston lower
- 3) Piston upper
- 4) Retaining clamp
- 5) Lantern
- 6) Screw retention
- 7) Piston rod
- 8) Screw
- 9) Hexagon screw
- 10) Actuator
- 11) Spindle
- 12) O-Ring
- 13) Position indication
- 14) Cap
- 15) Distance (DN65)

- D1) Seal  
 D2) Diaphragm  
 D3) Plain bearing  
 D4) O-Ring  
 D5) O-Ring
- G1 = Throat connection secured with  
 Lock nut removable (e.g. Loctite 243)
- B1 = Bore  
 L = Leakage tell taue G1/4

➤ **Wrench size**

	SW1	SW2	SW3	SW4	B1
DN40	19	27	17	17	ø7
DN50	19	27	17	17	ø7
DN65	19	24	17	17	ø7
DN80	27	30	17	17	ø8

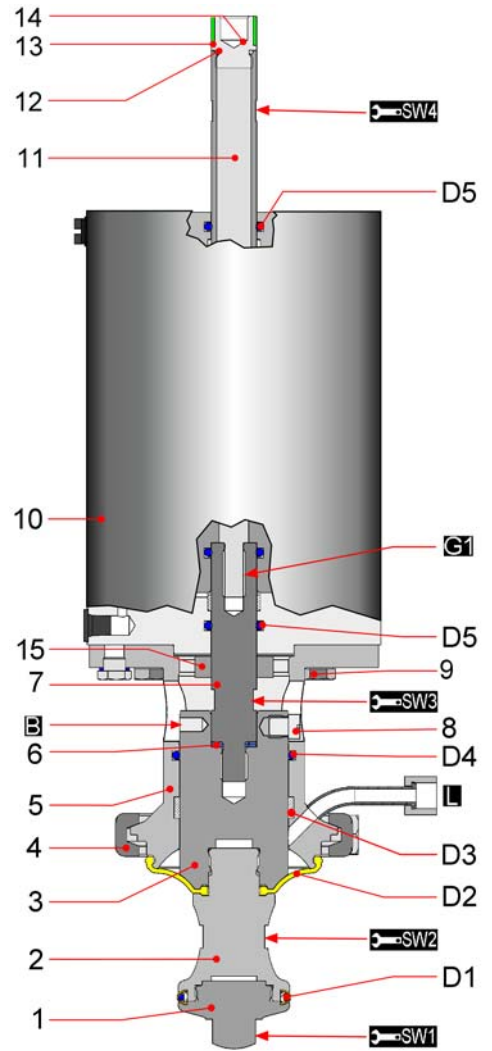
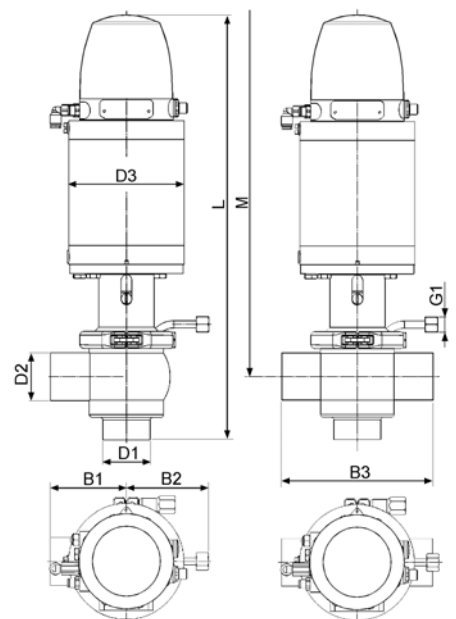

Fig. 9

**12.1 Dimensions**

Dimension nominal	DN40	DN 50	DN 65	DN 80	
D1	ø 41x1,5	ø 53x1,5	ø 70x2	ø 85x2	
D2	ø 41x1,5	ø 53x1,5	ø 70x2	ø 85x2	
D3	ø 129	ø 129	ø 167	ø 167	
B1	85	85	110	121	
B2	92	92	103	107	
B3	170	170	220	242	
L	536	631	629	681	
G1	1/4	1/4	1/4	1/4	
size when completed with Control head	M	520	540	625	686



## 13. Manufacturing

### 13.1 Structure of Article number

**5836 050 000 - 041**

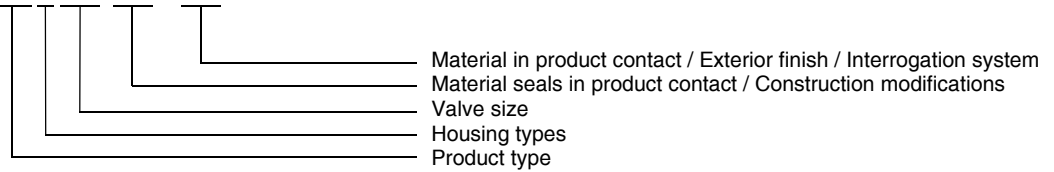

#### ➤ Product type

583x = GEMBRA Aseptic Single seat valve

#### ➤ Housing types

5836 Angle valve S-S | 5838 T-valve SS-S

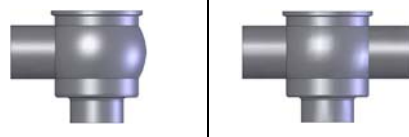

#### ➤ Valve size

DN = Nominal diameter

DIN	025 = DN25	040 = DN40	050 = DN50	065 = DN65	080 = DN80	100 = DN100	125 = DN125	150 = DN150
INCH	026 = DN1	038 = DN1½	051 = DN2	064 = DN2½	076 = DN3	101 = DN4	-	-

#### ➤ Material seals / Construction modifications

Material seals in product contact: PTFE / k-flex  
PTFE / EPDM

Construction modifications: Type of actuation - air open - spring close  
- air close - air close  
- spring open - air close

#### ➤ Material in product contact / Exterior finish

020 - 1.4301/1.4307 AISI304/307 - bright turned	040 - 1.4301/1.4307 AISI304/307 - bright turned
021 - 1.4301/1.4307 AISI304/307 - E-polished	041 - 1.4301/1.4307 AISI304/307 - E-polished
022 - 1.4301/1.4307 AISI304/307 - unpolished, glass-bead blasted	042 - 1.4301/1.4307 AISI304/307 - unpolished, glass-bead blasted

#### ➤ Interrogation system

Article number	Control System or Interrogation System (A1, A2)
58xx DN xxx -041	Valve without control- or interrogation system
58xx DN xxx -750	Valve with Sensor mounting set (5630 005 000-020)
58xx DN xxx -6xx	Control head ASi-Bus for GEMBRA-Single seat valves
58xx DN xxx -K6xx	Control head KI-Top ASi-Bus for GEMBRA-Single seat valves
58xx DN xxx -5xx	Control head SPS for GEMBRA-Single seat valves
58xx DN xxx -K5xx	Control head KI-Top SPS for GEMBRA-Single seat valves

DN - Nominal diameter e.g. 58xx 050 000-041

GEMBRA Aseptic Single seat valve Type: 583x

## 14. Spare parts list

### 14.1 GEMBRA Aseptic Single seat valve (1.4404 / AISI316L)

Type	Seal	Actuator	Article-No.	Valve insert VE	Housing VG AISI316L	Seal kit	
<b>Angle valve S-S</b>							
PTFE / k-flex		Lö - Fs	5836 DN 000-xxx	5836 DN 020-041		5836 DN 990-000	
		Fö - Ls	5836 DN 100-xxx	5836 DN 120-041			5835 DN 001-041
		Lö - Ls	5836 DN 300-xxx	5836 DN 320-041			
PTFE / EPDM		Lö - Fs	5836 DN 030-xxx	5836 DN 023-041		5836 DN 993-000	
		Fö - Ls	5836 DN 130-xxx	5836 DN 123-041			5835 DN 001-041
		Lö - Ls	5836 DN 330-xxx	5836 DN 323-041			
<b>T - valve SS-S</b>							
PTFE / k-flex		Lö - Fs	5838 DN 000-xxx	5836 DN 020-041		5836 DN 990-000	
		Fö - Ls	5838 DN 100-xxx	5836 DN 120-041			5837 DN 001-041
		Lö - Ls	5838 DN 300-xxx	5836 DN 320-041			
PTFE / EPDM		Lö - Fs	5838 DN 030-xxx	5836 DN 023-041		5836 DN 993-000	
		Fö - Ls	5838 DN 130-xxx	5836 DN 123-041			5837 DN 001-041
		Lö - Ls	5838 DN 330-xxx	5836 DN 323-041			

DN = Dimension nominal e.g. 5844 050 000-041  
 xxx = Control system - and interrogation system  
 MV = Solenoid valve  
 Lö = air open  
 Ls = air close  
 Fö = spring open  
 Fs = spring close

## 14.2 Valve insert

Item.	Designation	Material	DN40	DN50	DN65	DN80
VE	Valve insert L $\ddot{o}$ - Fs Valve insert F $\ddot{o}$ - Ls Valve insert L $\ddot{o}$ - Ls	PTFE / k-flex PTFE / k-flex PTFE / k-flex	5836 040 020-041 5836 040 120-041 5836 040 320-041	5836 050 020-041 5836 050 120-041 5836 050 320-041	5836 065 020-041 5836 065 120-041 5836 065 320-041	5836 080 020-041 5836 080 120-041 5836 080 320-041
VE	Valve insert L $\ddot{o}$ - Fs Valve insert F $\ddot{o}$ - Ls Valve insert L $\ddot{o}$ - Ls	PTFE / EPDM PTFE / EPDM PTFE / EPDM	5836 040 023-041 5836 040 123-041 5836 040 323-041	5836 050 023-041 5836 050 123-041 5836 050 323-041	5836 065 023-041 5836 065 123-041 5836 065 323-041	5836 080 023-041 5836 080 123-041 5836 080 323-041
1	Piston plate lower	AISI316L	5821 050 004-040	5821 050 004-040	5821 065 004-040	5821 080 004-040
2	Piston lower	AISI316L	5836 040 005-040	5836 050 005-040	5836 065 005-040	5836 080 005-040
3	Piston upper	AISI316L	5836 040 007-041	5836 040 007-041	5836 065 007-041	5836 080 007-041
4	Clamp coupling	AISI304	2122 065 100-020	2122 065 100-020	2122 115 100-020	2122 125 100-020
5	Lantern	AISI304	5821 050 014-021	5821 050 014-021	5821 065 014-021	5821 080 014-021
6	Washer screw retention	AISI316L	8135 012 195-040	8135 012 195-040	8135 012 195-040	8135 012 195-040
7	Piston rod	AISI303	5836 040 006-220	5836 040 006-220	5836 065 006-220	5836 080 006-220
8	Locking screw	AISI304	5836 040 008-020	5836 040 008-020	5836 040 008-020	5836 080 008-020
9	Hexagon screw (4x)	AISI304	8106 008 020-020	8106 008 020-020	8106 008 020-020	8106 008 020-020
10	Actuator L $\ddot{o}$ - Fs Actuator F $\ddot{o}$ - Ls Actuator L $\ddot{o}$ - Ls	AISI304 AISI304 AISI304	5200 129 151-032 5400 129 151-032 5300 129 151-032	5200 129 151-032 5400 129 151-032 5300 129 151-032	5200 167 151-032 5400 167 151-032 5300 167 151-032	5200 167 151-032 5400 167 151-032 5300 167 151-032
11	Spindle	AISI303	5622 100 070-220	5622 100 070-220	5622 100 070-220	5622 100 070-220
12	O-Ring	EPDM	2304 012 020-170	2304 012 020-170	2304 012 020-170	2304 012 020-170
13	Position indication	ABS gn	5622 100 058-152	5622 100 058-152	5622 100 058-152	5622 100 058-152
14	Cap	AISI303	5622 100 071-220	5622 100 071-220	5622 100 071-220	5622 100 071-220
15	Distance	AISI304	-	-	5836 065 010-020	-

## 14.3 Seal kit

	Seal kit PTFE / EPDM Seal kit PTFE / k-flex	PTFE/EPDM PTFE/k-flex	5836 050 993-000 5836 050 990-000	5836 050 993-000 5836 050 990-000	5836 065 993-000 5836 065 990-000	5836 080 993-000 5836 080 990-000
D1	Type: PTFE/EPDM ----- Type: PTFE/k-flex k-flex Seal - Ring quartered - O-Ring - k-flex Seal	EPDM ----- k-flex AISI304 EPDM k-flex	5621 050 020-084 ----- 5621 050 020-114 5621 050 021-020 2304 044 030-159 5621 050 022-114	5621 050 020-084 ----- 5621 050 020-114 5621 050 021-020 2304 044 030-159 5621 050 022-114	5621 065 010-084 ----- 5621 065 010-114 5621 065 011-020 2304 060 026-159 5621 065 012-114	5621 080 010-084 ----- 5621 080 010-114 5621 080 011-020 2304 076 026-159 5621 080 012-114
D2	Diaphragm	PTFE	5821 050 020-053	5821 050 020-053	5821 065 020-053	5821 080 020-053
D3	Piston guide bush	PTFE	8051 250 010-081	8051 250 010-081	8051 190 010-081	8051 220 010-081
D4	O-Ring	EPDM	2304 049 035-170	2304 049 035-170	2304 062 035-159	2304 072 035-170
D5	O-Ring (2x)	EPDM	2304 019 035-171	2304 019 035-171	2304 019 035-171	2304 019 035-171



## Declaration of conformity

Translation of the original

*Manufacturer / authorised representative:*

KIESELMANN GmbH  
Paul-Kieselmann-Str. 4-10  
75438 Knittlingen  
Germany

Authorised representative,  
for compiling technical documents:

Achim Kauselmann  
KIESELMANN GmbH  
Paul-Kieselmann-Str. 4-10  
75438 Knittlingen  
Germany

Product name	Function
pneum. Lift actuators	Stroke movement
pneum. Rotary actuators	Rotary movement
Ball valves	Media cutoff
Butterfly valves	Media cutoff
Single seat valves	Media cutoff
Flow control valves	Control of liquefied media
Throttle valve	Control of liquefied media
Overflow valve	Definition of fluid pressure
Double seat valve	Media separation
Bellow valves	Sampling of liquids
Sampling valves	Sampling of liquids
Two way valves	Media cutoff
Tankdome fitting	Prevention of overpressure and vacuum, Tank cleaning

The manufacturer hereby states that the above product is considered as an incomplete machine in the sense defined in the Directive 2006/42/EC on Machinery. The above product is exclusively intended to be installed into a machine or an incomplete machine. The said product does not yet conform to all the relevant requirements defined in the Directive on Machinery referred to above for this reason.

The specific technical documents listed in Appendix VII, Part B, have been prepared. The Authorized Agent empowered to compile technical documents may submit the relevant documents if such a request has been properly justified.

Commissioning of an incomplete machine may only be carried out if it has been determined that the respective machine into which the incomplete machine is to be installed conforms to the regulations set out in the Directive on Machinery referred to above.

The above product conforms to the requirements of the directives and harmonized standards specified below:

- DIN EN ISO 12100 Safety of machinery

Knittlingen, 04. 10. 2012

Klaus Dohle

General Director